

LECTURE 1

INTRODUCTION TO MACHINE

DRAWING

1. Graphic Language

A technical person can use the graphic language as powerful means of communication with others for conveying ideas on technical matters. However, for effective exchange of ideas with others, the engineer must have proficiency in (i) language, both written and oral, (ii) symbols associated with basic sciences and (iii) the graphic language. Engineering drawing is a suitable graphic language from which any trained person can visualize the required object. As an engineering drawing displays the exact picture of an object, it obviously conveys the same ideas to every trained eye.

Irrespective of language barriers, the drawings can be effectively used in other countries, in addition to the country where they are prepared. Thus, the engineering drawing is the universal language of all engineers.

2. Importance of Graphic Language

The graphic language had its existence when it became necessary to build new structures and create new machines or the like, in addition to representing the existing ones. In the absence of graphic language, the ideas on technical matters have to be conveyed by speech or writing, both are unreliable and difficult to understand by the shop floor people for manufacturing. This method involves not only lot of time and labor, but also manufacturing errors. Without engineering drawing, it would have been impossible to produce objects such as aircrafts, automobiles, locomotives, etc., each requiring thousands of different components.

3. Need for Correct Drawings

The drawings prepared by any technical person must be clear, unmistakable in meaning and there should not be any scope for more than one interpretation, or else litigation may arise. In a number of dealings with contracts, the drawing is an official document and the success or failure of a structure depends on the clarity of details provided on the drawing. Thus, the drawings should not give any scope for misinterpretation even by accident.

It would not have been possible to produce the machines/automobiles on a mass scale where a number of assemblies and sub-assemblies are involved, without clear, correct and accurate drawings. To achieve this, the technical person must gain a thorough knowledge of both the principles and conventional practice of drawing. If these are not achieved and or practiced, the drawings prepared by one may convey different meaning to others, causing unnecessary delays and expenses in production shops.

Hence, an engineer should possess good knowledge, not only in preparing a correct drawing but also to read the drawing correctly.

4. Classifications of Drawings

4.1 Machine Drawing

It is pertaining to machine parts or components. It is presented through a number of orthographic views, so that the size and shape of the component is fully understood. Part drawings and assembly drawings belong to this classification. There are two types of machine drawing:

4.1.1 Part Drawing

Component or part drawing is a detailed drawing of a component to facilitate its manufacture. All the principles of orthographic projection and the technique of graphic representation must be followed to communicate the details in a part drawing. Fig. 1 shows an example of part drawing (Note that the drawing was drawn according to a different drawing standard)

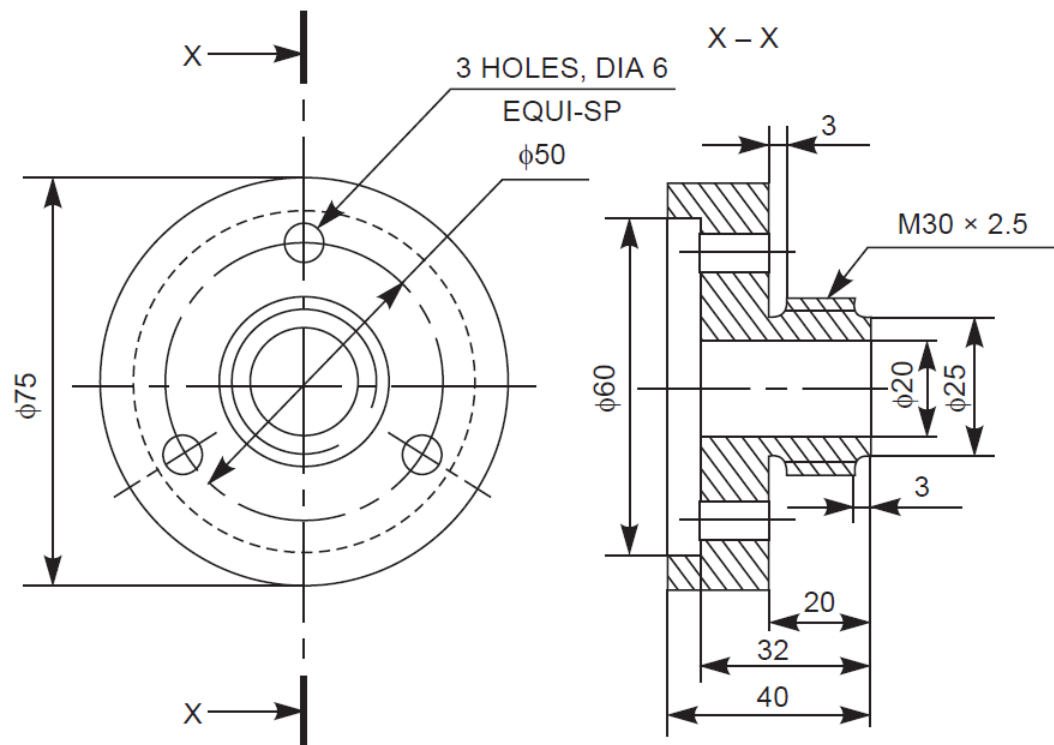

Fig. 1 Part drawing of a machine component.

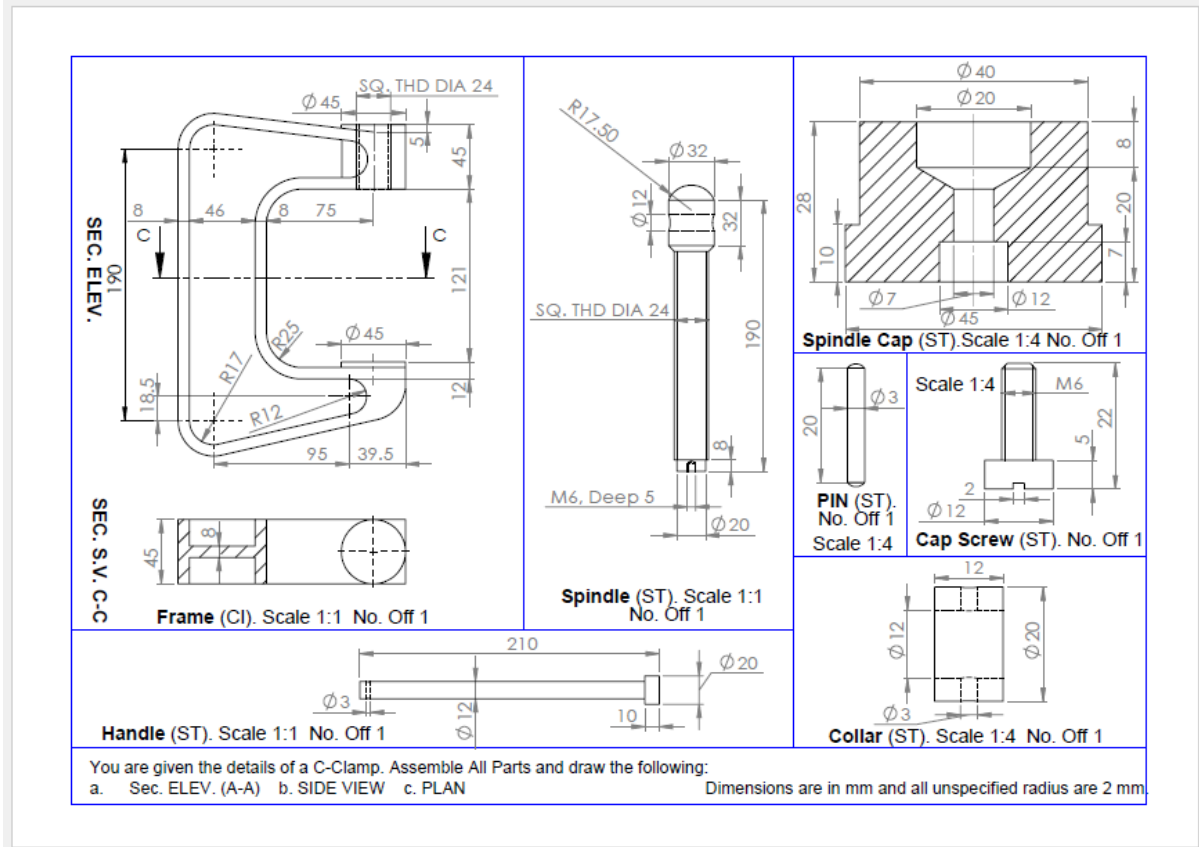
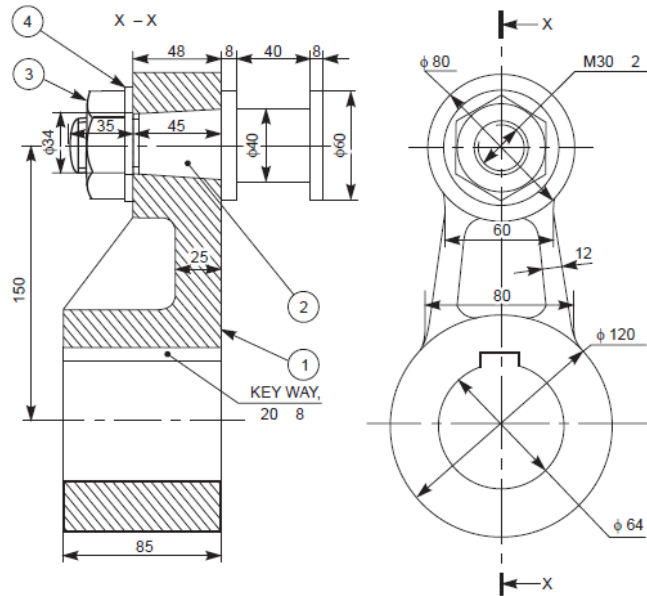

Fig. 2. Part drawing Examples.

4.1.2 Assembly Drawing

A drawing that shows the various parts of a machine in their correct working locations is an assembly drawing. Fig. 3 shows an example of an assembly drawing (Note that the drawing was drawn according to a different drawing standard).



Parts List

Part No.	Name	Material	Qty
1	Crank	Forged Steel	1
2	Crank Pin	45C	1
3	Nut	MS	1
4	Washer	MS	1

Fig. 3. Assembly drawing of a machine.

The assembly drawing can be shown in exploded view as shown in the Fig. 4.

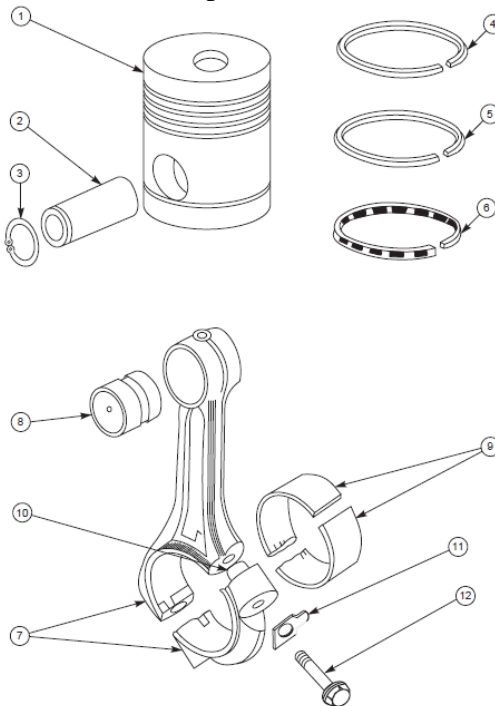

Fig. 4. Exploded view drawing of a machine.

4.1.3 Production Drawing

A production drawing, also referred to as working drawing, should furnish all the dimensions, limits and special finishing processes such as heat treatment, honing, lapping, surface finish, etc., to guide the craftsman on the shop floor in producing the component. The title should also mention the material used for the product, number of parts required for the assembled unit, etc. Fig. 5 shows an example of a production drawing (Note that the drawing was drawn according to a different drawing standard)

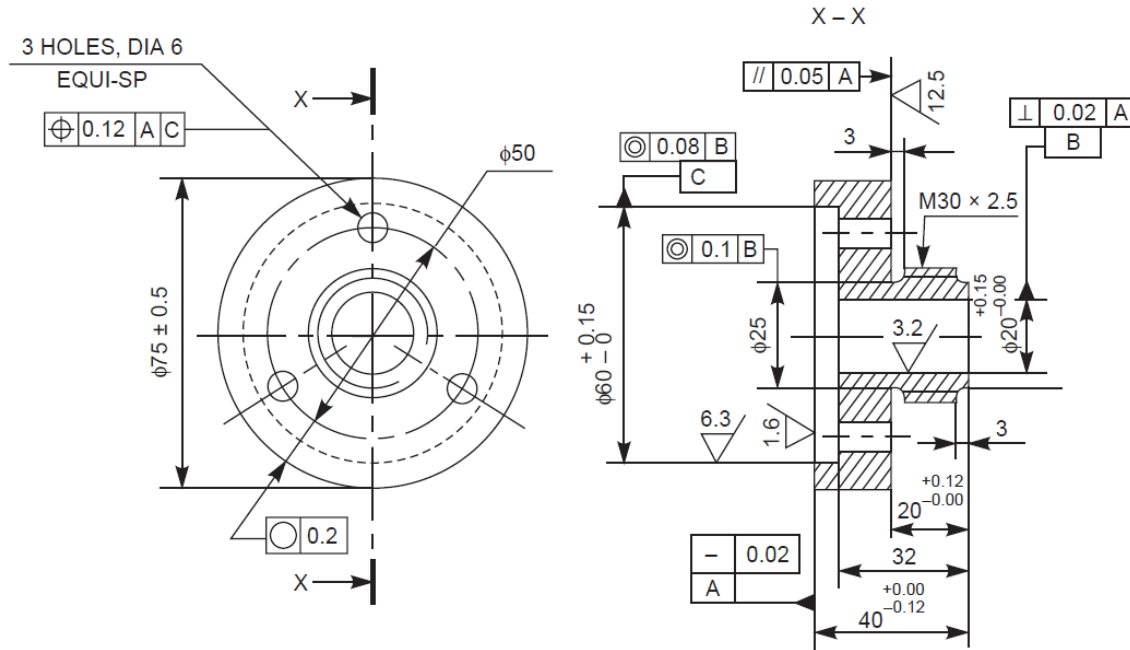

Fig. 5. Production drawing of a machine component

An assembly drawing of a fuel injector for a diesel engine. Drawn to BS and ISO Standards, as shown in Fig. 6, this is a typical professional CAD drawing which could be produced using most CAD software on the market.

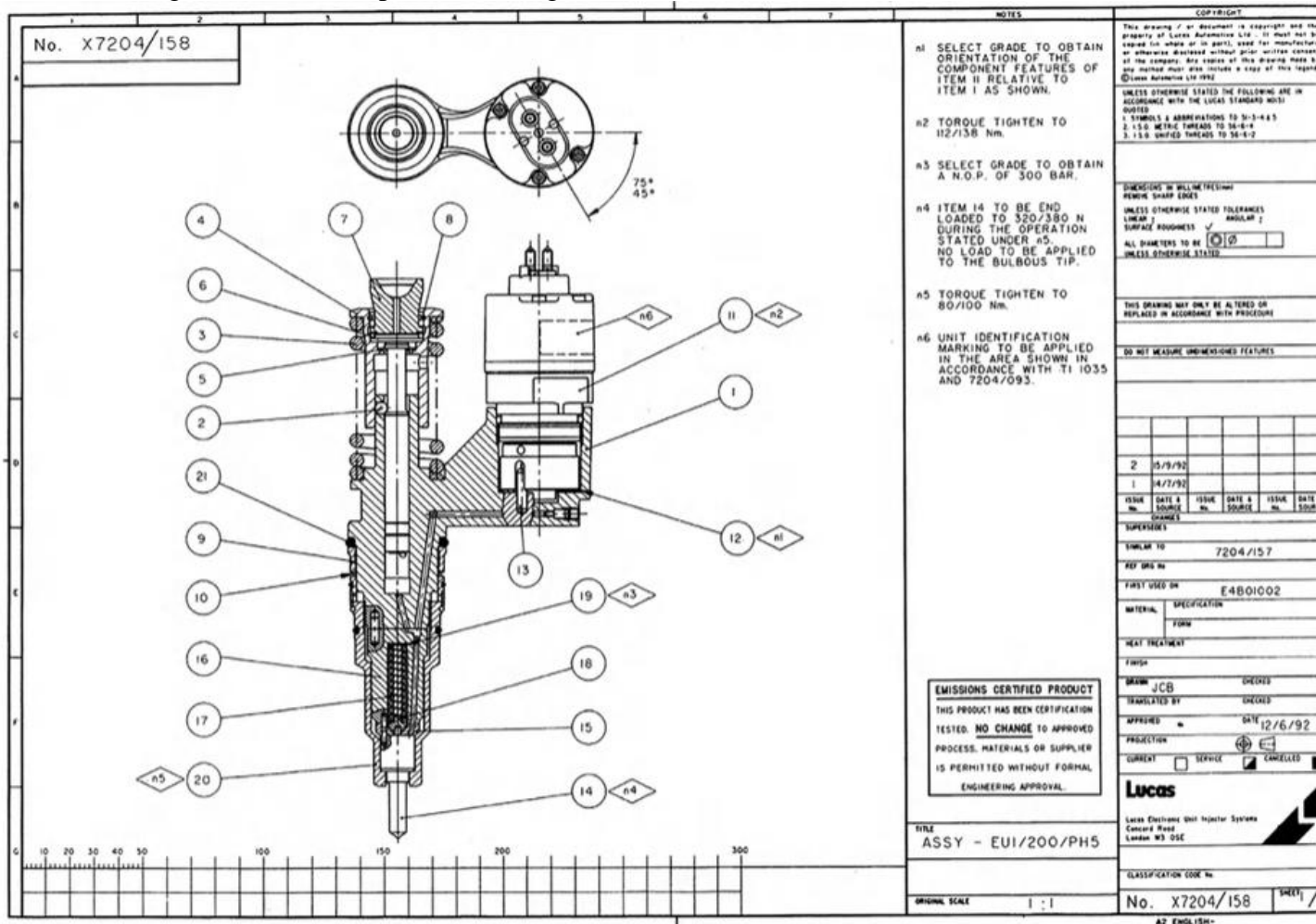
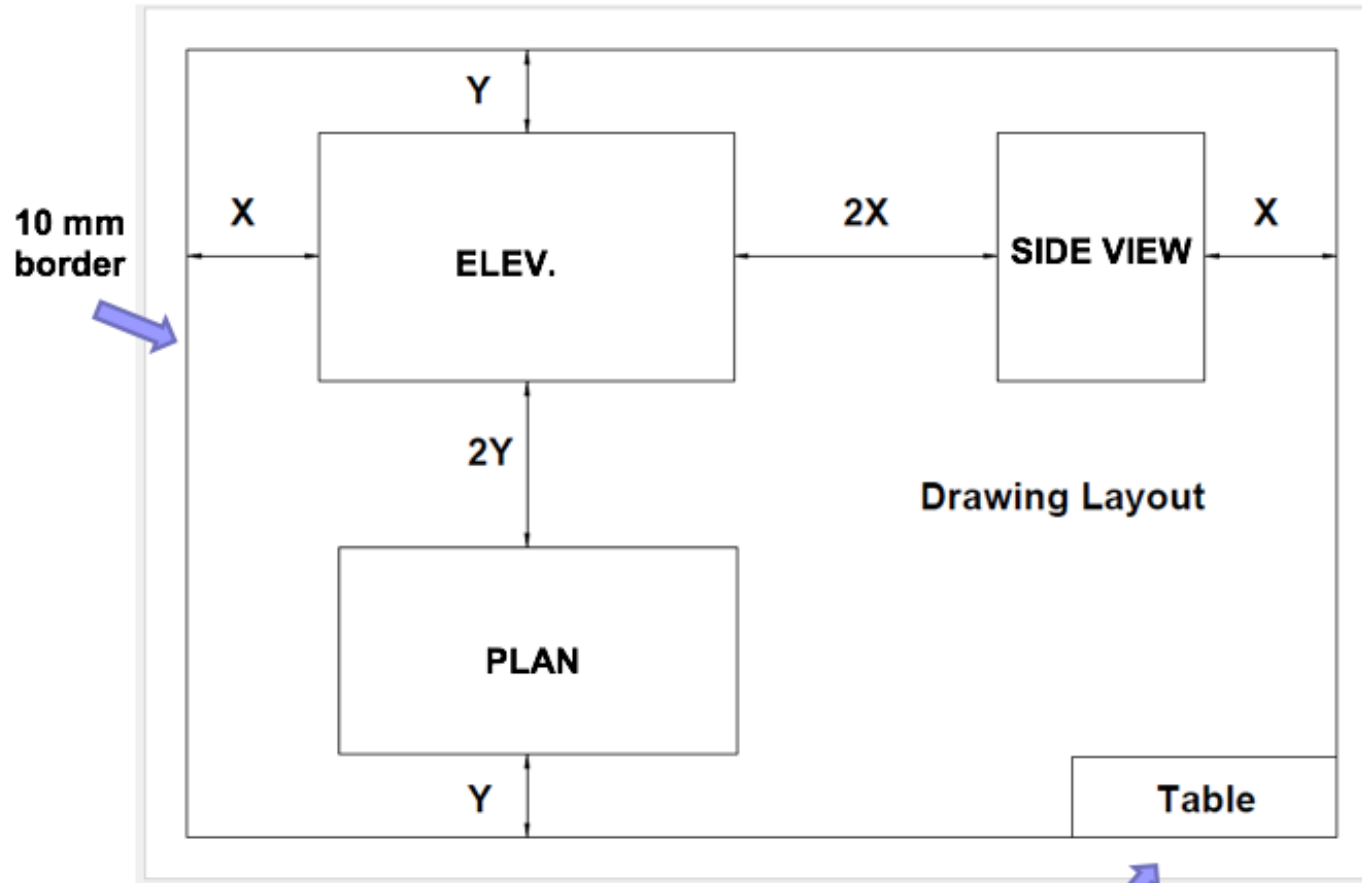

Fig. 6. Part drawing of a machine component.

5. Drawing Layout
5.1 Drawing Layout



Write your name and seat number here with Blue ink

Fig. 7. Drawing Layout.

5.2 Drawing Layout Example

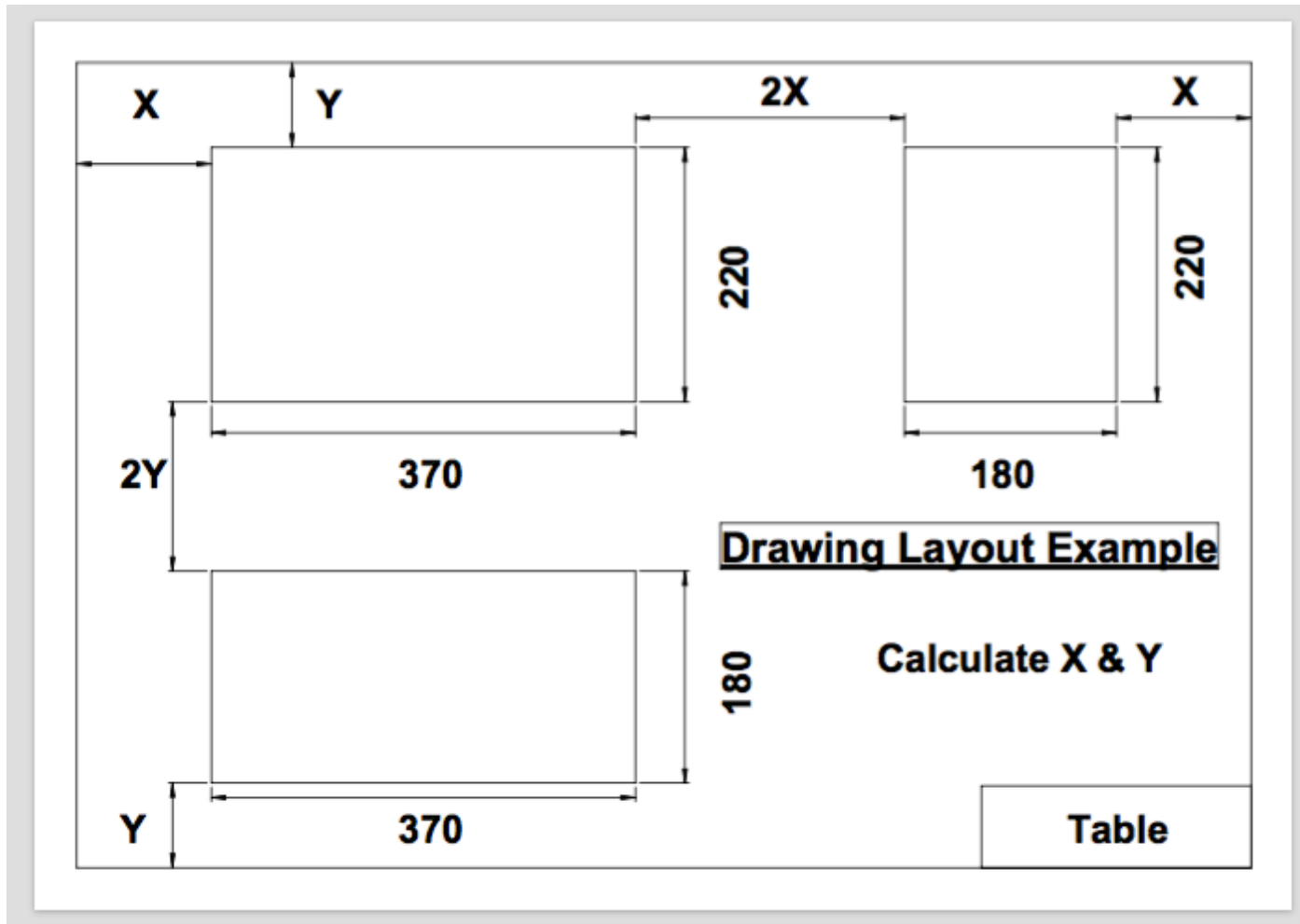

Fig. 8. Drawing Layout Example.

5.3 Drawing Layout example solution

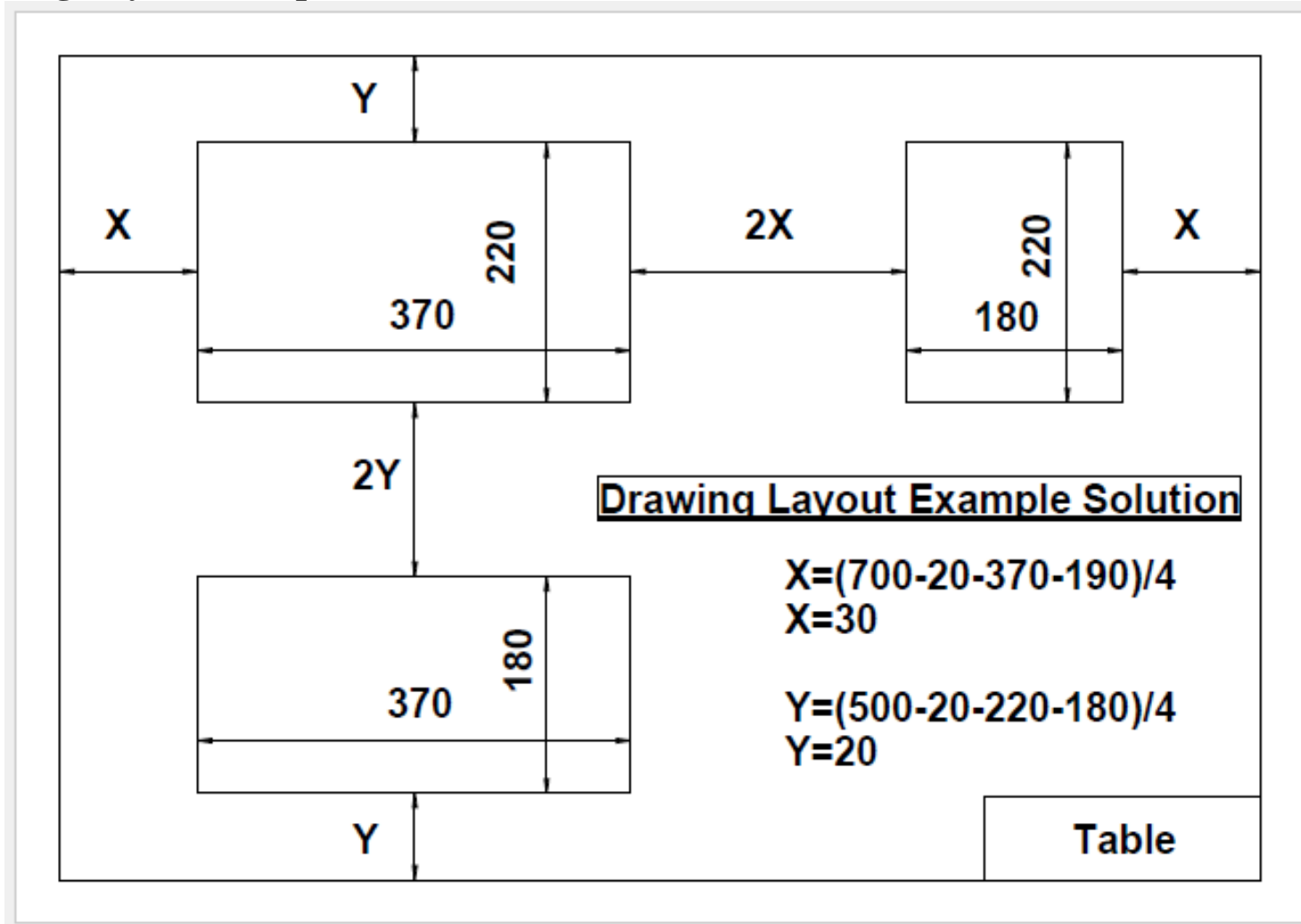

Fig. 9. Drawing Layout Example Solution.

5.4 Table dimensions

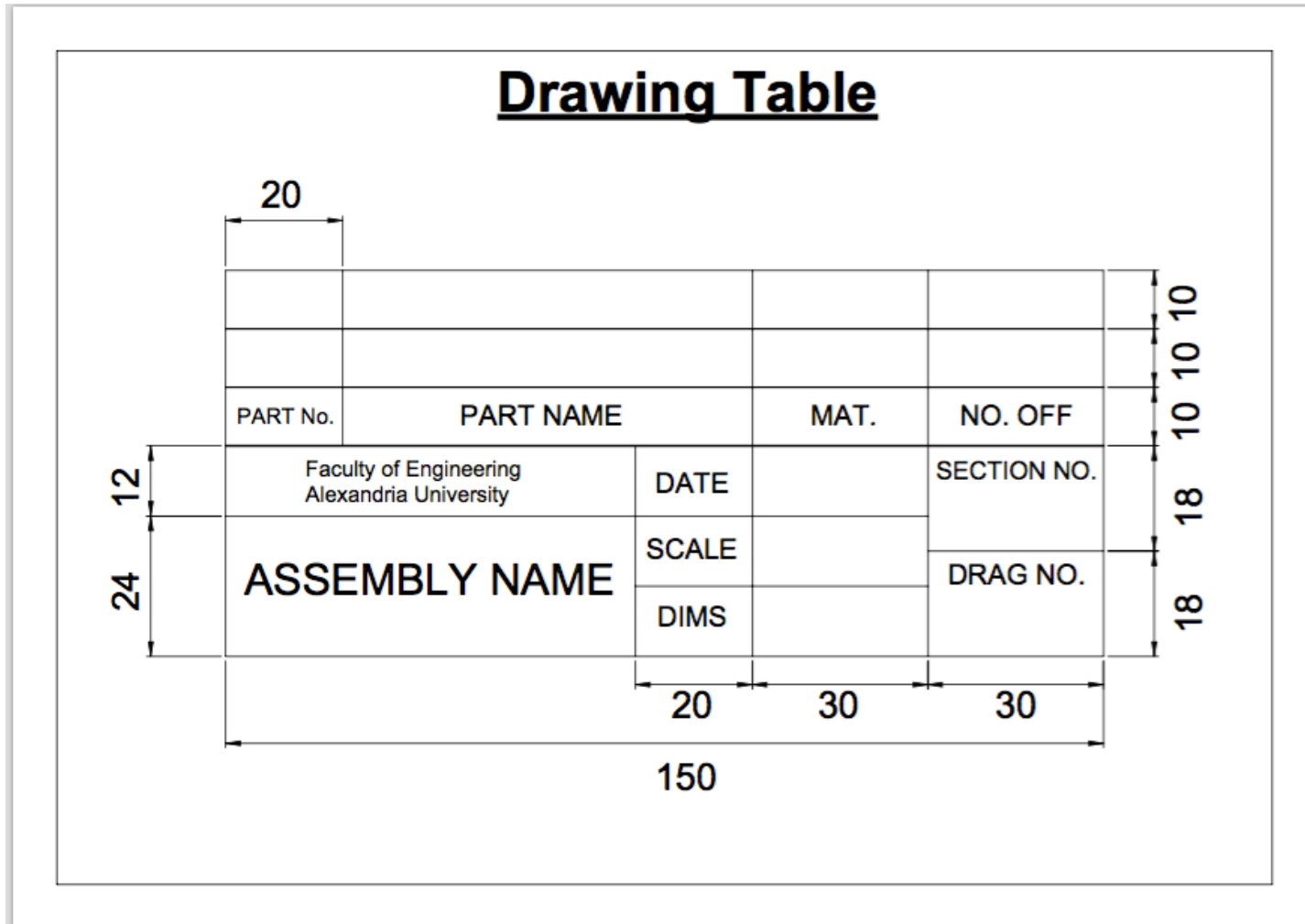

Fig. 10. Drawing Table.

5.5 An example of filled table

Drawing Table - filled

	20				
	2	PIN	ST	3	10
	1	FRAME	CI	1	10
	PART No.	PART NAME	MAT.	NO. OFF	10
12	Faculty of Engineering Alexandria University		DATE	1/10/2015	SECTION NO.
24	C-CLAMP		SCALE	1:1	DRAG NO. 1
			DIMS	mm	
		20	30	30	18
	150				

Fig. 11. Filled-Drawing Table.

6. Drawing Conventions

6.1. Line Types

Example	Type	Description and Representation		Application
A	01.2	Continuous wide line	1	Visible edges and outlines
			2	Crests of screw threads and limit of length of full depth thread
			3	Main representations on diagrams, maps, and flow charts
			4	Lines of cuts and sections
B	01.1	Continuous narrow line	1	Dimension, extension, and projection lines
			2	Hatching lines for cross-sections
			3	Leader and reference lines
			4	Outlines of revolved sections
			5	Imaginary lines of intersection
			6	Short centre lines
			7	Diagonals indicating flat surfaces
			8	Bending lines
			9	Indication of repetitive features
			10	Root of screw threads
			11	Indication of repetitive features
C	01.1	Continuous narrow irregular line		Limits of partial views or sections provided the line is not an axis
D	02.1	Dashed narrow line		Hidden outlines and edges
E	04.1	Long-dashed dotted narrow line	1	Centre lines
			2	Lines of symmetry
			3	Pitch circle for gears
			4	Pitch circle for holes
			5	Cutting planes (see F [04.2] for ends and changes of direction)
F	04.2	Long-dashed dotted wide line	1	Surfaces which have to meet special requirements
			2	Cutting planes at ends and changes of direction (see E 04.1)
G		Long-dashed dotted narrow line with wide line at ends and at changes to indicate cutting planes		Note BS EN ISO 128-24 shows a long-dashed dotted wide line for this application
H	05.1	Long-dashed double dotted narrow line	1	Outlines of adjacent parts
			2	Extreme positions of movable parts
			3	Initial outlines prior to forming
			4	Outline of finished parts within blanks
			5	Projected tolerance zones
			6	Parts situated at the front of a cutting plane
			7	Framing of particular fields or areas
			8	Centroidal lines
			9	Outlines of alternative executions
J	01.1	Continuous straight narrow line with zig-zags		Limits of partial or interrupted views

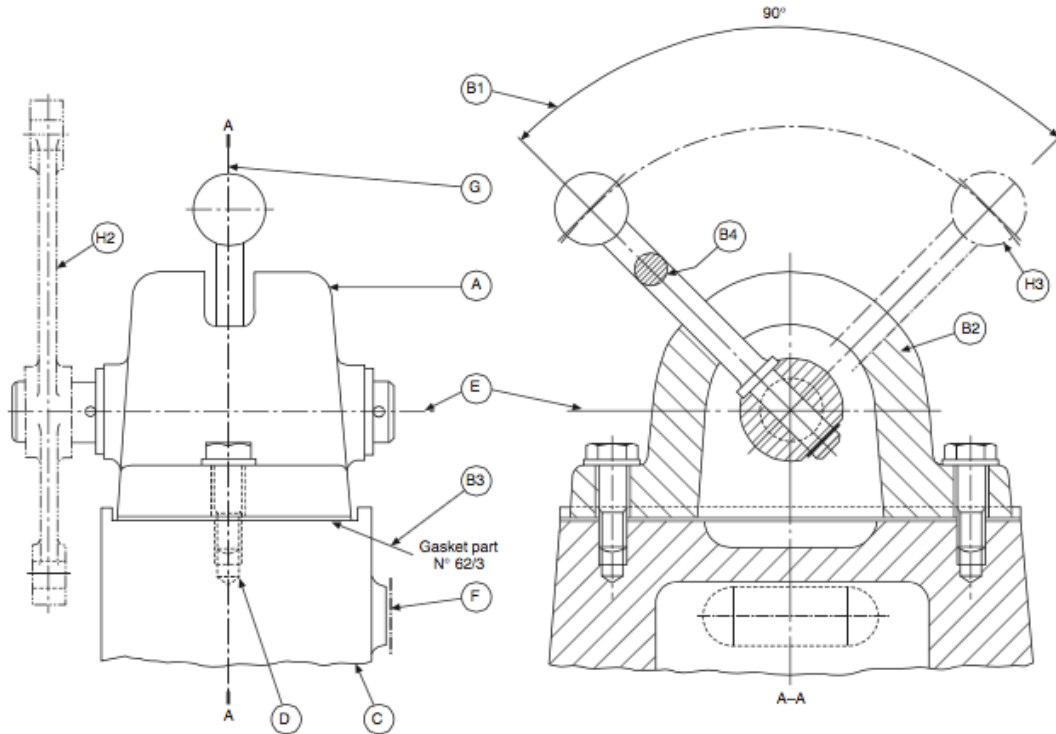

Fig. 12. Example of different line types.

Interrupted view application

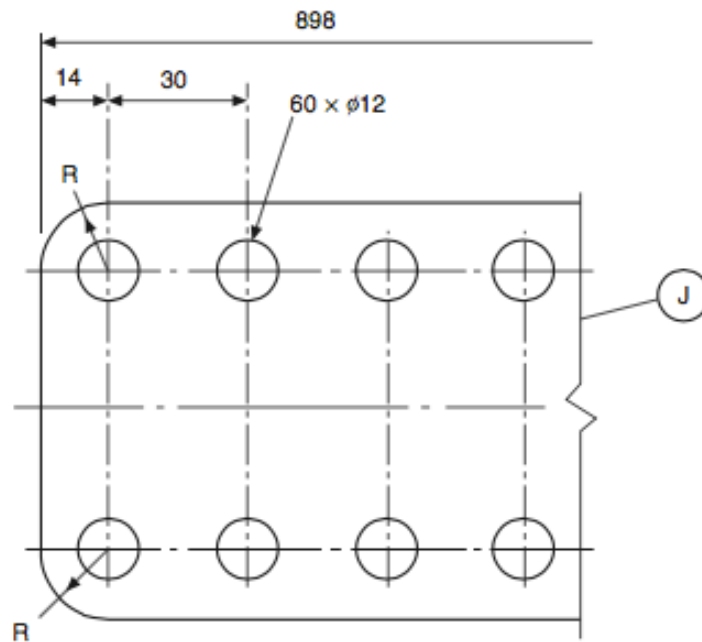

Fig. 13. Interrupted view example.

6.2 Part numbering

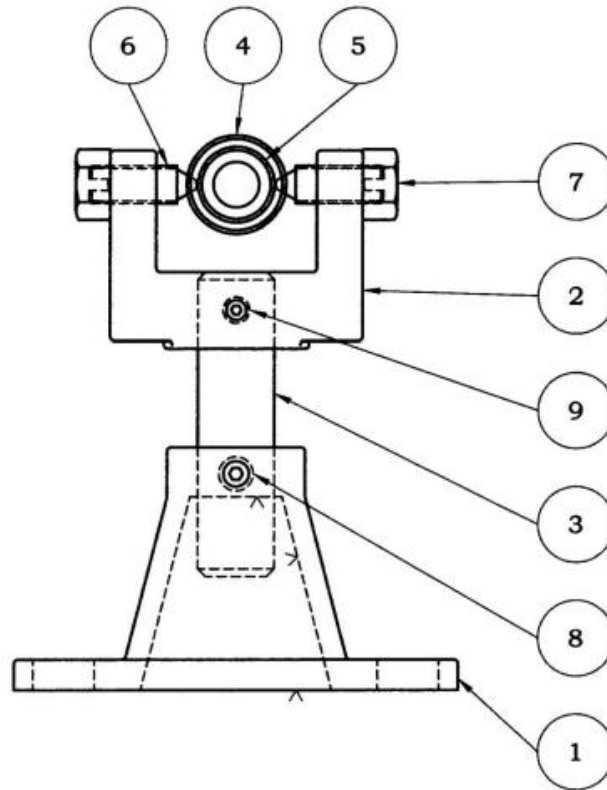
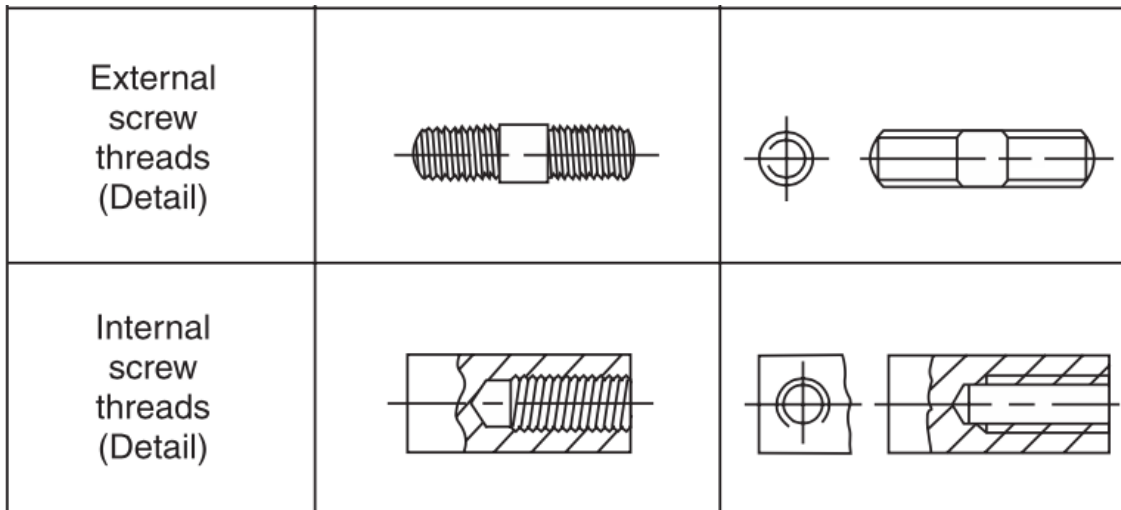

Fig. 14. Part Numbering Example.

6.3 Drawing conventions

<p>Square on shaft</p>		
------------------------	--	--



6.4 Abbreviations for Materials

Material	Abbreviation
Aluminum	AL
Bronze	BRZ
Cast Iron	C.I.
Stainless Steel	ST.

7. Lettering

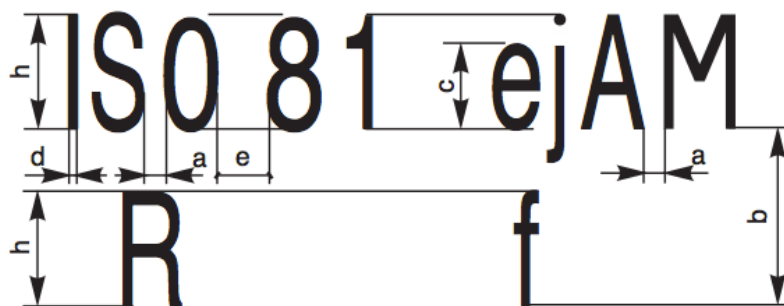

<i>Characteristic</i>	<i>Ratio</i>	<i>Dimensions, (mm)</i>							
Lettering height (Height of capitals)	h (14/14) h	2.5	3.5	5	7	10	14	20	
Height of lower-case letters (without stem or tail)	c (10/14) h	—	2.5	3.5	5	7	10	14	
Spacing between characters	a (2/14) h	0.35	0.5	0.7	1	1.4	2	2.8	
Minimum spacing of base lines	b (20/14) h	3.5	5	7	10	14	20	28	
Minimum spacing between words	e (6/14) h	1.05	1.5	2.1	3	4.2	6	8.4	
Thickness of lines	d (1/14) h	0.18	0.25	0.35	0.5	0.7	1	1.4	

8. Hatching Review

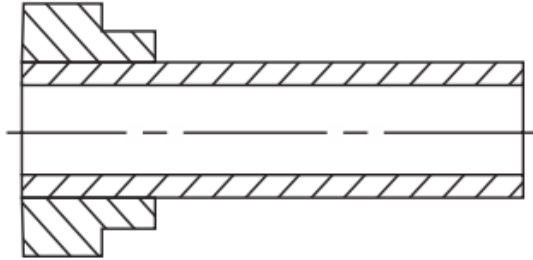

Fig. 15. Hatching of two adjacent parts.

8.1 Sections not to be hatched

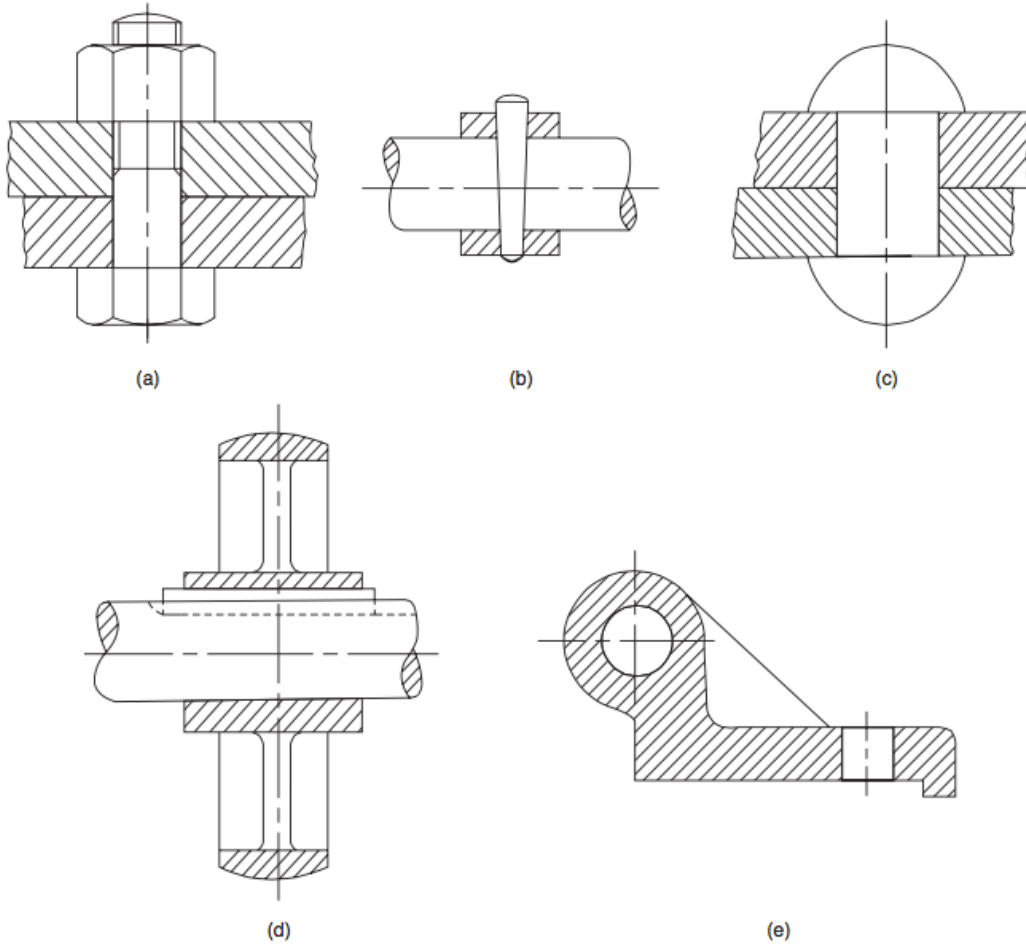

Fig. 16. Example of sections.

Indicate the correct and incorrect methods of sectioning of machine elements represented in Fig. 14.

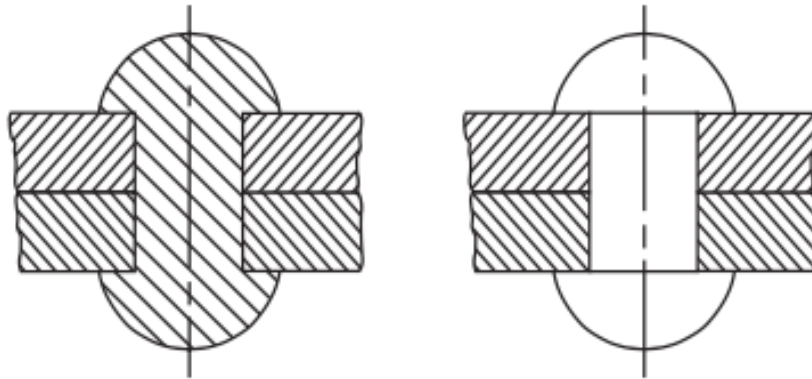

Fig. 17. Hatching of two adjacent parts.

Indicate the correct and incorrect methods of sectioning of machine elements represented in Fig. 15.

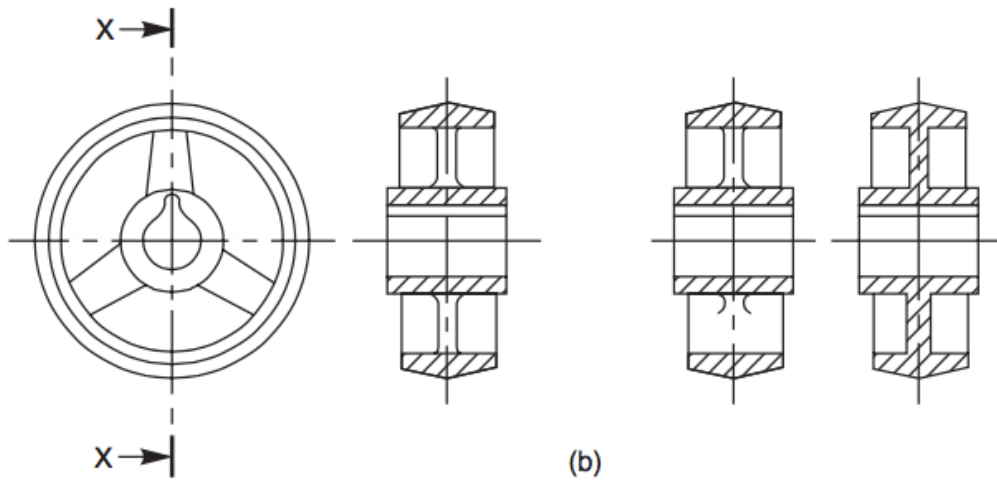

Fig. 18. Hatching of two adjacent parts.

Indicate the correct and incorrect methods of sectioning of machine elements represented in Fig. 19.

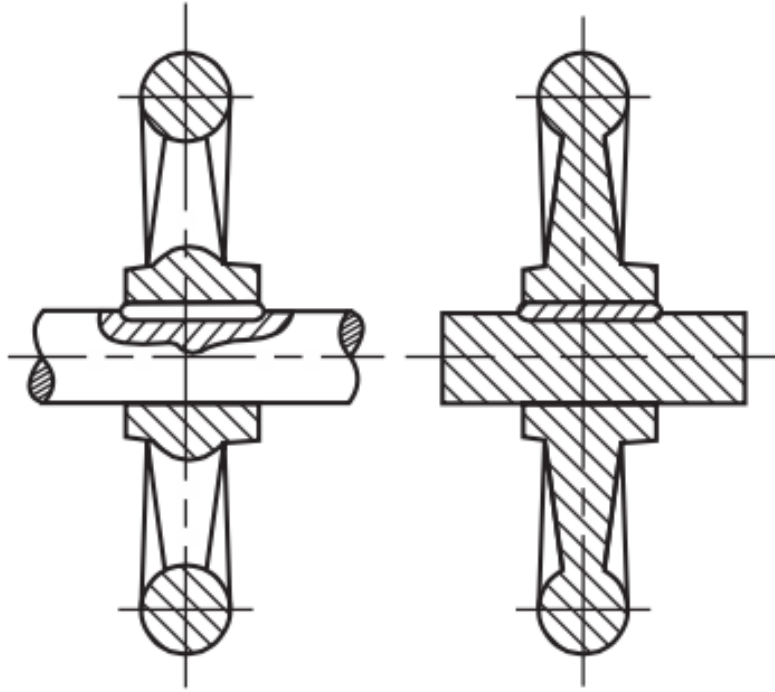

Fig. 19. Hatching of two adjacent parts.

9. Sectional View

A sectional view is obtained by imagining the object, as if cut by a cutting plane and the portion between the observer and the section plane being removed. Figure 4.1a shows an object, with the cutting plane passing through it and Fig., the two halves drawn apart, exposing the interior details.

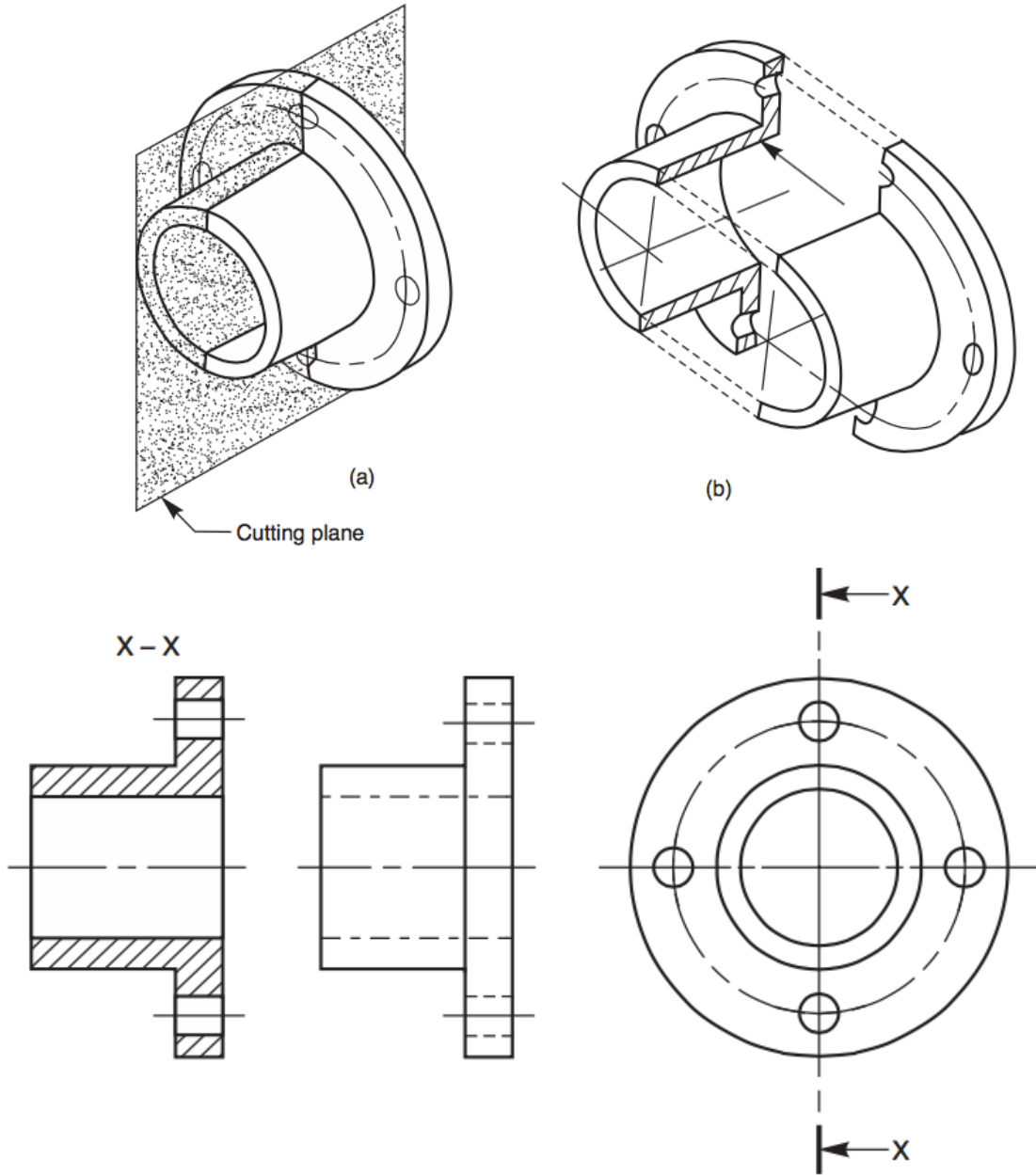

Fig. 20. Section Example.

Indicate the correct and incorrect methods of sectioning of machine elements represented in Fig. 19.

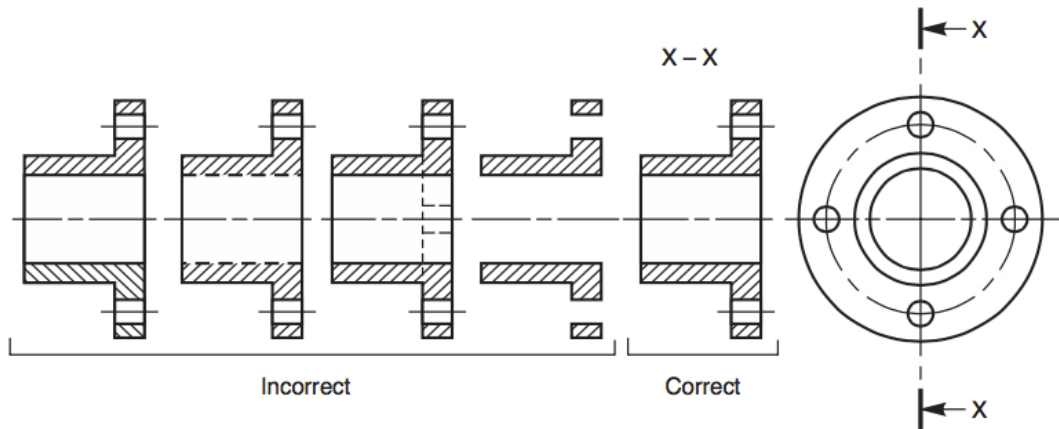

Fig. 21. Correct and incorrect section views.

Half Section

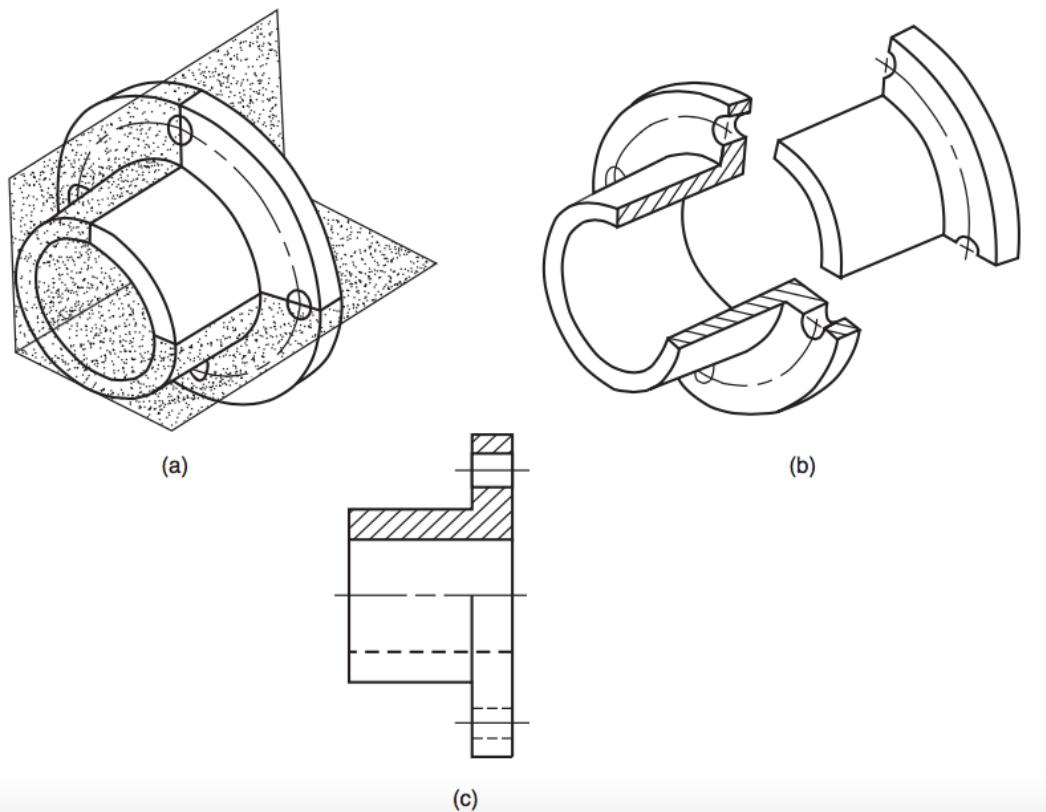

Fig. 22. Half Section Example.

10. First and Third Angel Projection

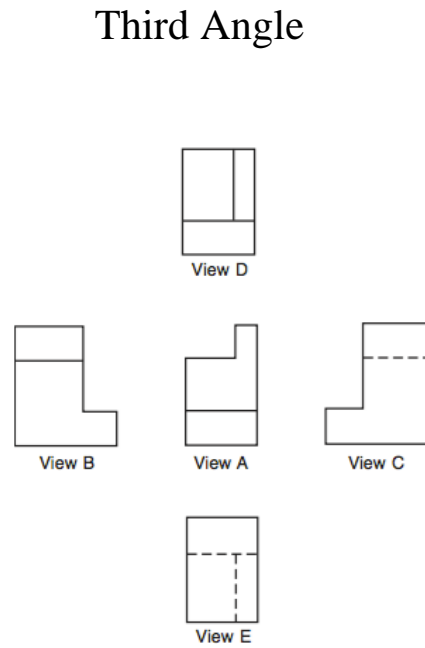
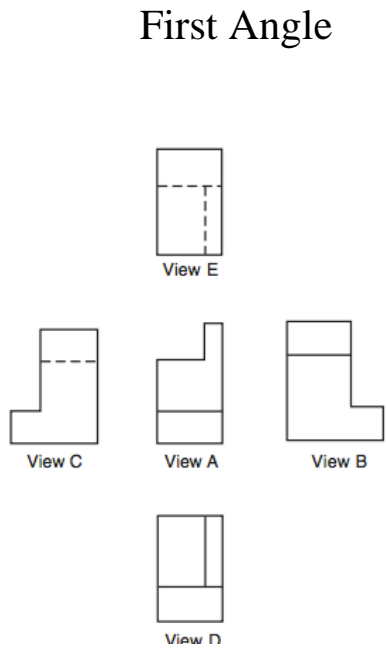
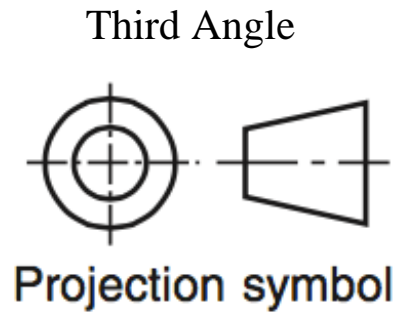
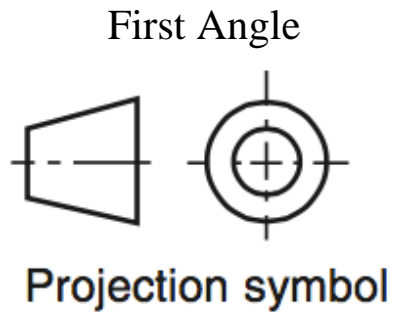

Fig. 23. First and Third Angel Projection.

KNUCKLE JOINT

Knuckle joint is a type of mechanical joint used in structures, to connect two intersecting cylindrical rods, whose axes lie on the same plane. It permits some angular movement between the cylindrical rods (in their plane). It is specially designed to withstand tensile loads.

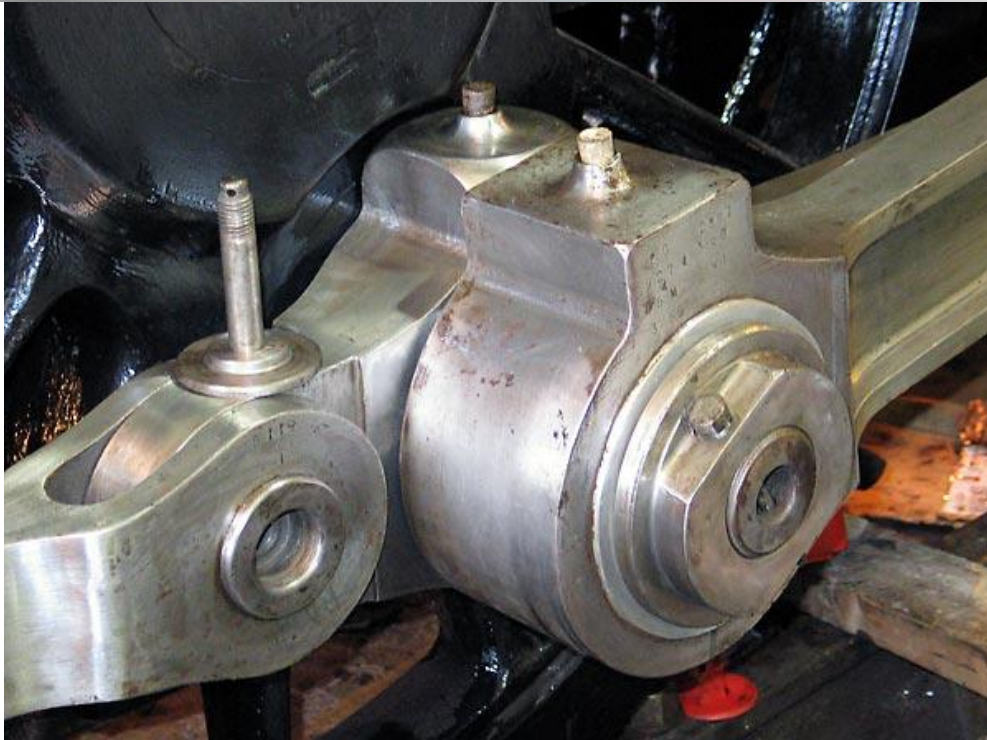
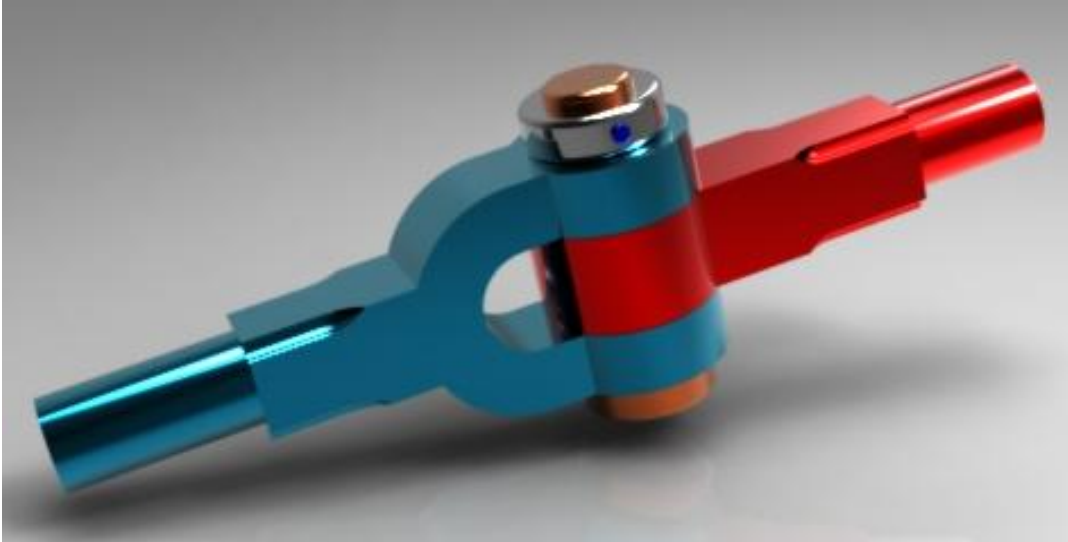

Fig. 24. Knuckle Joint Examples.

Applications of Knuckle Joint

Tractors

Trains

Automobile wipers

Cranes

Robotic joints

Advantages of Knuckle Joint:

Knuckle joint can withstand large tensile loads.

It has good mechanical rigidity.

It is easy to manufacture and set up.

It can be easily dismantled and assembled.

Design is simple and easy.

Disadvantages of Knuckle Joint:

The joint cannot withstand large compressive loads.

It permits angular movement in only one plane.

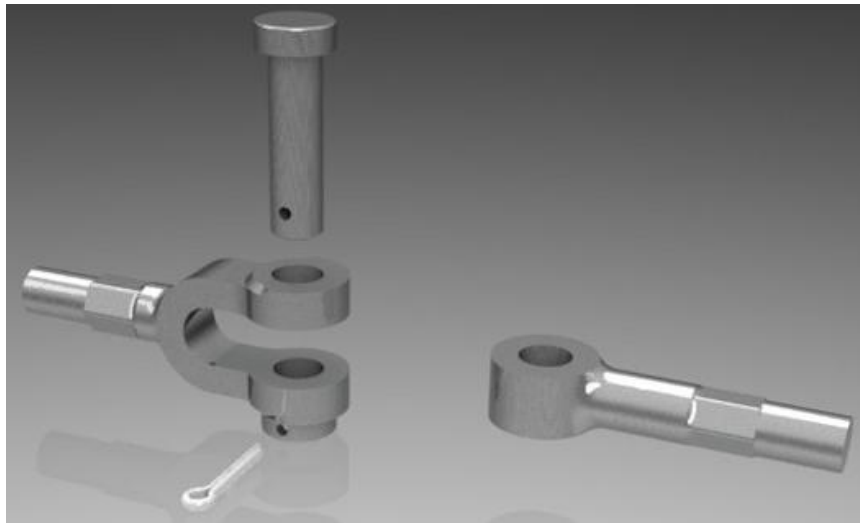

Fig. 25. Assembly of Knuckle Joint.

Split Pin



Fig. 26. Split Pin.